

Technical Data Sheet



Radiant Heating & Cooling Panels

Solray Ceiling Panel 4GC:S

4 Guillotined Edges, Steel Tubes

High Security, Steel Faced

Data Sheet 7-1

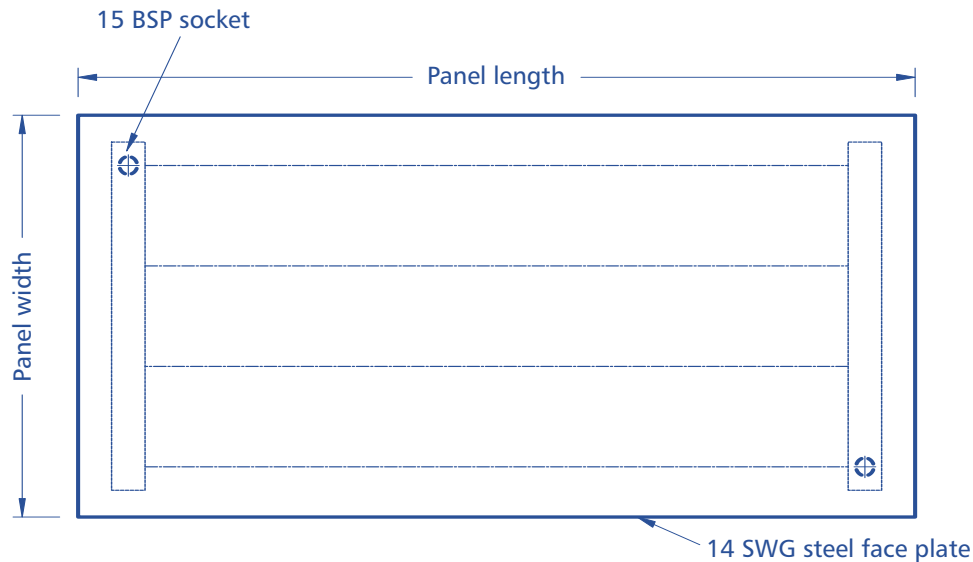

Plan

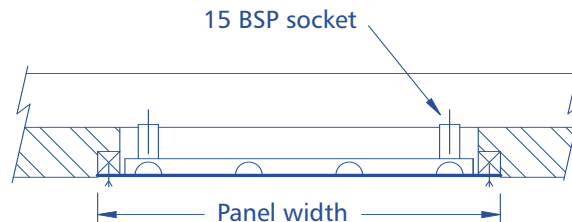

Section

NOTES

Panels finished in a primer for final painting on site by others with the first coat being applied prior to installation, or in a factory applied textured powdercoat to any standard colour.

Panels insulated with 50mm glass fibre class 'o' backed mattress.

Panels to be complete with angle cleats at approximately 300mm centres for fixing with hook bolts.

Connections are 15mm, 20mm or 25mm BSP sockets.

Panels to vent through connections.

All edges guillotined.

Panel viewed from face (i.e. looking up at the ceiling).

Panels tested to 700 kPa at works.

Panel mass is approximately 40 kg/m².

COMYN CHING & CO. (SOLRAY) LTD

SOLRAY WORKS, MANILLA STREET, DOCKLANDS, LONDON E14 8LG

TEL: 020 7987 8787 FAX: 020 7987 9898

WWW.SOLRAY.CO.UK E-MAIL: SALES@SOLRAY.CO.UK

Technical Data Sheet



Radiant Heating & Cooling Panels

Solray Ceiling Panel 4RC:S

4 Returned Edges, Steel Tubes

High Security, Steel Faced

Data Sheet 7-2

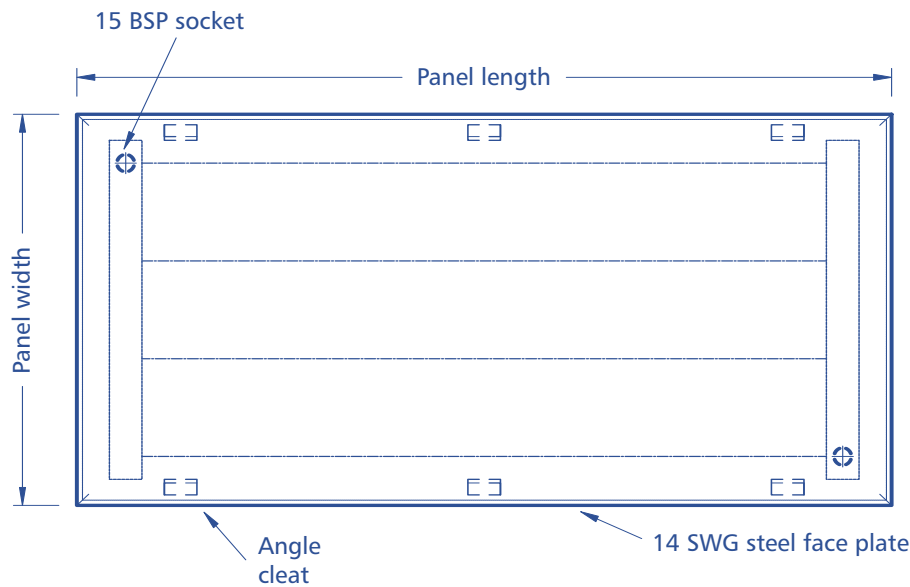

Plan

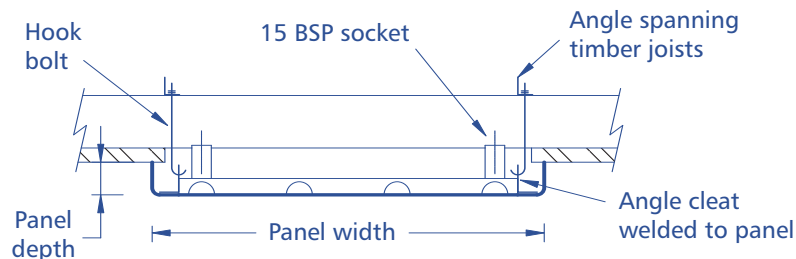

Section

NOTES

Panels finished in a primer for final painting on site by others with the first coat being applied prior to installation, or in a factory applied textured powdercoat to any standard colour.

Panels insulated with 50mm glass fibre class 'o' backed mattress.

Panels to be complete with angle cleats at approximately 600mm centres for fixing with hook bolts.

Connections are 15mm, 20mm or 25mm BSP sockets. Panels to vent through connections.

All edges with rolled or folded return.

Mitred corners can be rounded bull nose if required.

Panel viewed from face (i.e. looking up at the ceiling).

Panels tested to 700 kPa at works.

Panel mass is approximately 40 kg/m².

COMYN CHING & CO. (SOLRAY) LTD

SOLRAY WORKS, MANILLA STREET, DOCKLANDS, LONDON E14 8LG

TEL: 020 7987 8787 FAX: 020 7987 9898

WWW.SOLRAY.CO.UK E-MAIL: SALES@SOLRAY.CO.UK

Technical Data Sheet



Solray Ceiling Panel 1RC1C:S

Radiant Heating & Cooling Panels

1 Returned Edge, 1 Cover Plate, Steel Tubes

High Security, Steel Faced

Data Sheet 7-3

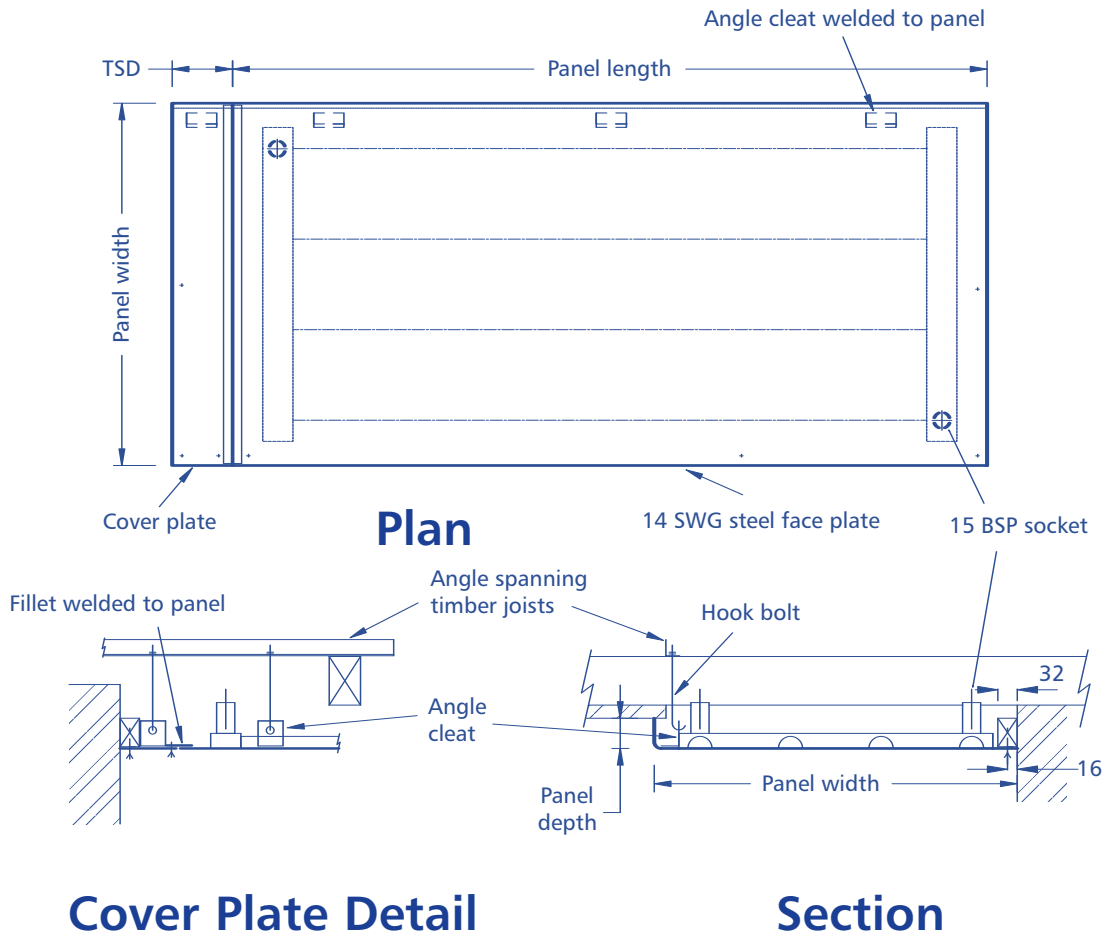

NOTES

Panels finished in a primer for final painting on site by others with the first coat being applied prior to installation, or in a factory applied textured powdercoat to any standard colour. Timber grounds by others.

Panels insulated with 50mm glass fibre class 'o' backed mattress.

Panels to be complete with angle cleats at approximately 600mm centres for fixing with hook bolts.

Panels drilled at approximately 300mm centres along guillotined edges for fixing with No.7 countersunk wood screws.

Connections are 15mm, 20mm or 25mm BSP sockets. Panels to vent through connections.

Front edge returned; others guillotined.

Cover plate manufactured to site dimensions (TSD) after panel is fixed.

Cover plate fixed to panel with M4 countersunk set screws.

Panel viewed from face (i.e. looking up at the ceiling).

Panels tested to 700 kPa at works.

Panel mass is approximately 40kg/m².

COMYN CHING & CO. (SOLRAY) LTD

SOLRAY WORKS, MANILLA STREET, DOCKLANDS, LONDON E14 8LG

TEL: 020 7987 8787 FAX: 020 7987 9898

WWW.SOLRAY.CO.UK E-MAIL: SALES@SOLRAY.CO.UK

Technical Data Sheet



Radiant Heating & Cooling Panels

Solray Ceiling Panel 4GC:C

Copper Tubes

Standard Security, Steel Faced

Data Sheet 7-4

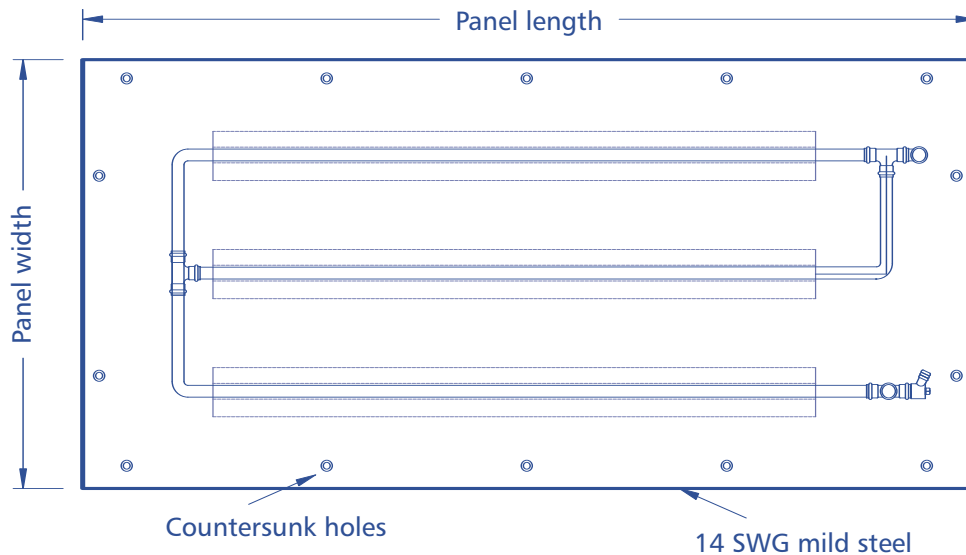

Plan View

NOTES

Panels finished in a primer for final painting on site by others with the first coat being applied prior to installation, or in a factory applied textured powdercoat to any standard colour.

Panels insulated with 50mm glass fibre class 'o' backed mattress.

Panels fixed at 300mm centres using No. 7 counter-sunk security screws.

Connections are 15mm, 20mm or 25mm BSP copper tails.

All edges guillotined.

Panel mass is approximately 40 kg/m².

Panels tested to 700 kPa at works.

Panels can be powder coated to any standard RAL colour on request.

COMYN CHING & CO. (SOLRAY) LTD

SOLRAY WORKS, MANILLA STREET, DOCKLANDS, LONDON E14 8LG

TEL: 020 7987 8787 FAX: 020 7987 9898

WWW.SOLRAY.CO.UK E-MAIL: SALES@SOLRAY.CO.UK

Technical data sheet



Solray ceiling panel 4RC1C

4 Returned edges

Standard security, steel faced

Data sheet 7-1

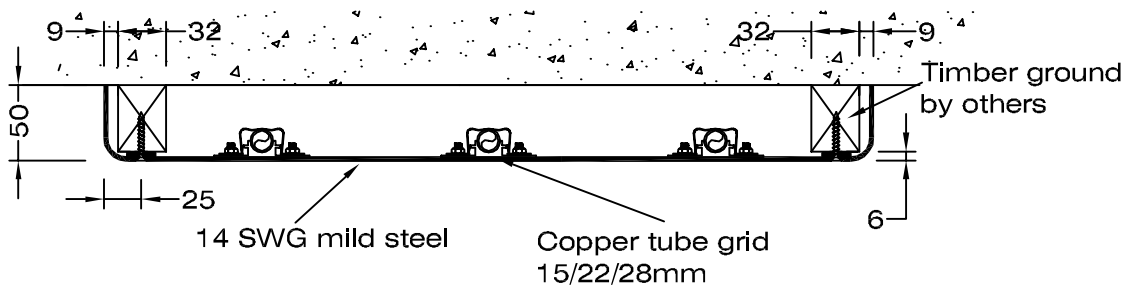

Scale 1:5

Notes:

Panels finished in a primer for final painting on site by others with the first coat being applied prior to installation, or in a factory applied textured powdercoat to any standard colour.

Timber grounds by others.

Panels insulated with 50mm glass fibre class 'o' backed matress.

Panels fixed at 300mm centres using No. 7 countersunk security screws.

Connections are 15mm, 20mm or 25mm BSP sockets.

All edges are rolled

Panel mass is approximately 40kg/m².

Panels tested to 700kPa at works.

Panels can be powder coated to any standard RAL colour on request.

COMYN CHING & CO. (SOLRAY) LTD

PHEONIX WAY, GARNGOCH INDUSTRIAL ESTATE,
GORSEINON, SWANSEA, SA4 9WF

TEL:01792 89 22 11 FAX:01792 89 88 55 WWW.SOLRAY.CO.UK

E-MAIL: SALES@SOLRAY.CO.UK

Technical Data Sheet



Radiant Heating & Cooling Panels

Solray Ceiling Panel 1RC1C:C Copper Tubes

Standard Security, Steel Faced

Data Sheet 7-6

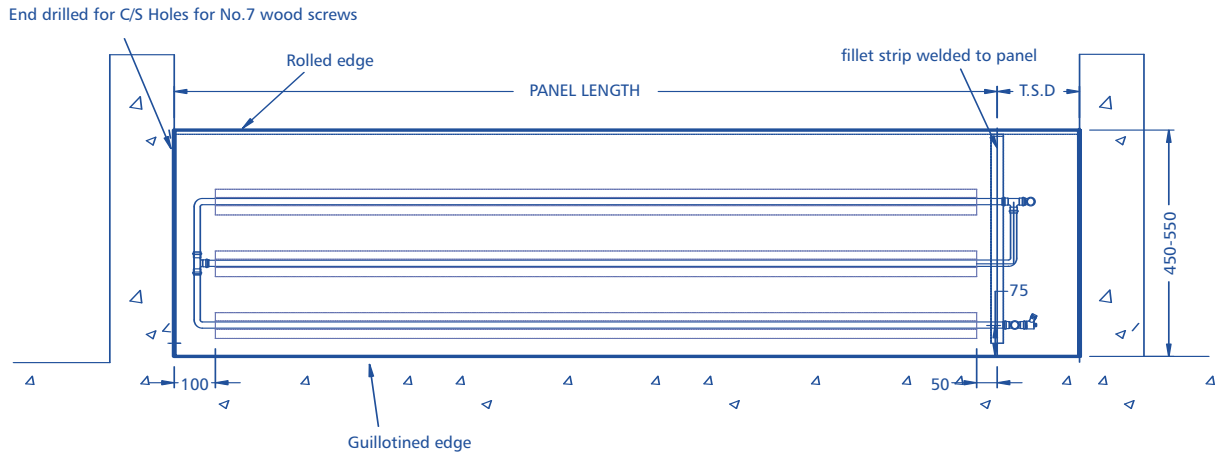

Plan

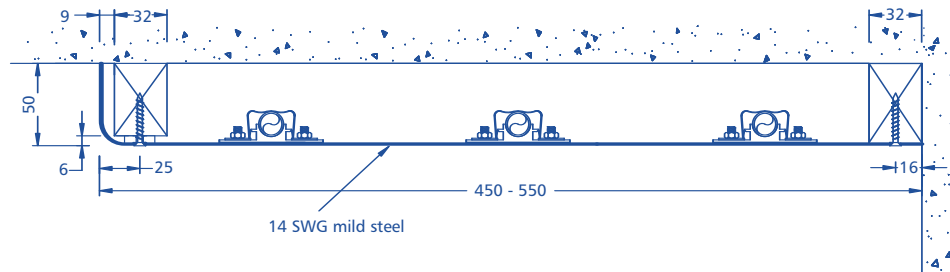

Section

NOTES

Panels finished in a primer for final painting on site by others with the first coat being applied prior to installation, or in a factory applied textured powdercoat to any standard colour.

Panels insulated with 50mm glass fibre class 'o' backed mattress.

Panels fixed at 300mm centres using No. 7 counter-sunk security screws.

Connections are 15mm, 20mm or 25mm BSP sockets.

All edges guillotined.

Panel mass is approximately 40 kg/m².

Panels tested to 700 kPa at works.

Panels can be powder coated to any standard RAL colour on request.

COMYN CHING & CO. (SOLRAY) LTD

SOLRAY WORKS, MANILLA STREET, DOCKLANDS, LONDON E14 8LG

TEL: 020 7987 8787 FAX: 020 7987 9898

WWW.SOLRAY.CO.UK E-MAIL: SALES@SOLRAY.CO.UK

Technical Data Sheet

Solray Ceiling Panel 2RC:C Copper Tubes

Standard Security, Steel Faced

Data Sheet 7-7

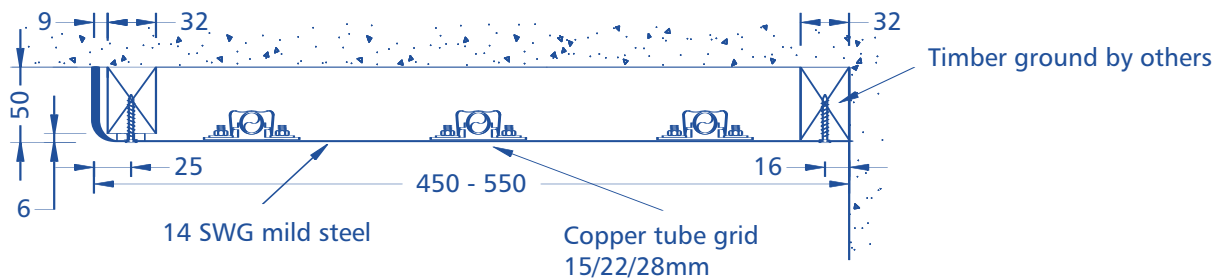

Typical Panel Section

NOTES

Panels finished in a primer for final painting on site by others with the first coat being applied prior to installation, or in a factory applied textured powdercoat to any standard colour.

Panels insulated with 50mm glass fibre class 'o' backed mattress.

Panels fixed at 300mm centres using No. 7 counter-sunk security screws.

Connections are 15mm, 20mm or 25mm BSP sockets.

All edges guillotined.

Panel mass is approximately 40 kg/m².

Panels tested to 700 kPa at works.

Panels can be powder coated to any standard RAL colour on request.

Technical Data Sheet



Radiant Heating & Cooling Panels

Solray Steel Panel

4GC-C 600 Wide

Guillotined Steel Faceplate

Data Sheet

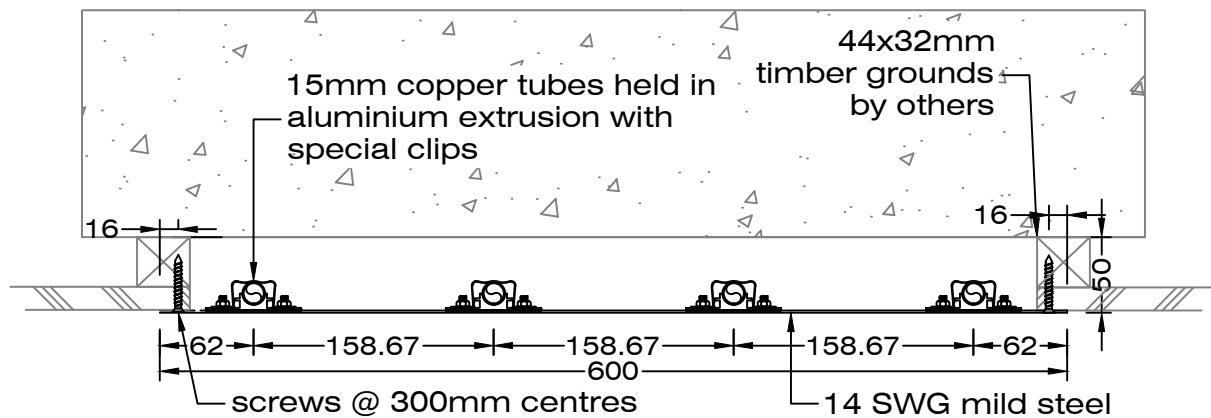

600mm, 4GC Panel Section Detail

1:5

Notes

Panels finished in a primer for final painting on site by others with the first coat being applied prior to insulation, or in the factory applied textured powder coat to any standard colour.

Panels insulated with 50mm glass fiber class 'o' backed mattress.

Mass approximately 40kg/m²

Panels tested to 700 kPa at works.